

VENTILATION

EXHAUST FANS FOR AGRICULTURAL AND INDUSTRIAL APPLICATIONS

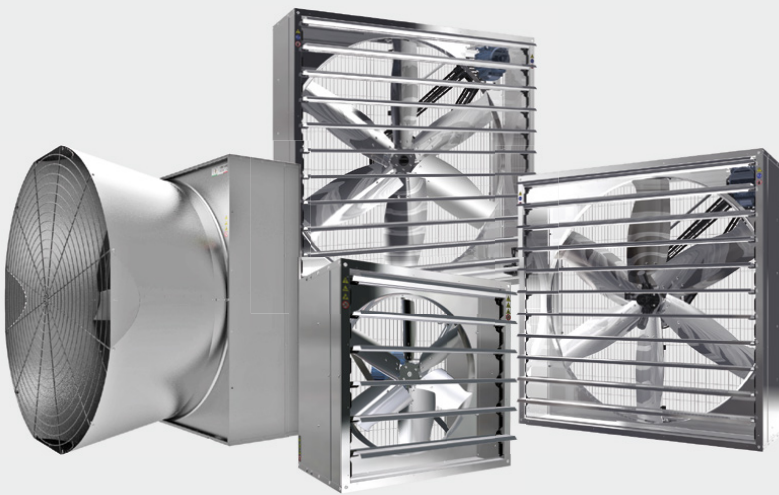

since
1967

 **TERMOTECNICA®**
PERICOLI

EOS EWS

BELT-DRIVEN EXHAUST FAN

Exhaust fan specifically designed for high airflow capacity. Available in 42" and 53", their main features are great efficiency and low maintenance costs.

The fan housing is available in galvanized or stainless steel (Aeternum EWS 53 only) for the maximum corrosion resistance. The entire line is tested in our PERIlab and certified by BessLab.

Choice of two patented opening systems

EOS FLAP SYSTEM

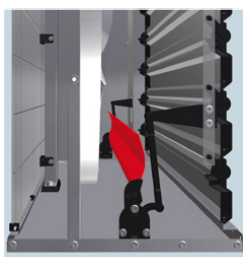

Closed shutter

Exclusive opening



Open shutter

EWS CENTRIFUGAL SYSTEM

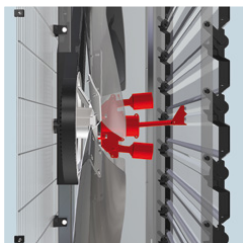

Closed shutter

Conventional opening

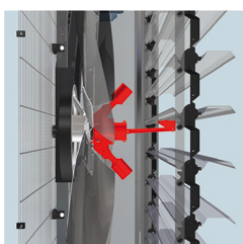

Open shutter

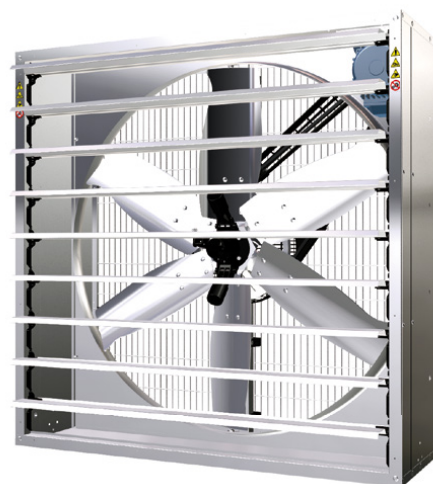

Features and advantages

EOS EWS

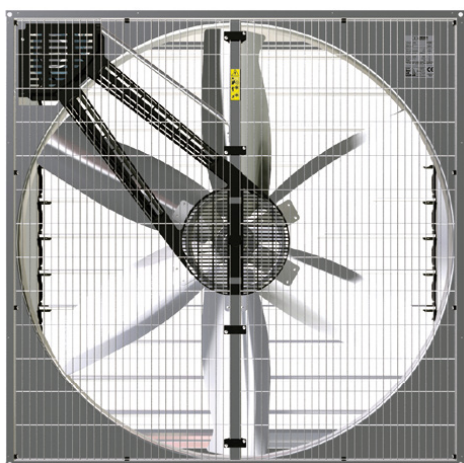

Effective protection from light and air thanks to the gaskets, which guarantee a perfect closure of the blades



SK optional external safety netting



Fixing threaded bush (M8)



Bottom panel with 4 practical water discharge holes



Easy opening guards



Pre-tensioned V-belt

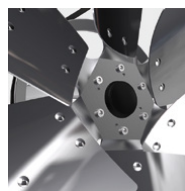

Propeller hub in steel with corrosion protection



Plastic safety guard on drive belt (CE option)

EOS / EWS 53 - test number Bess Lab: 10090; 10092; 10094; 10097; 10106; 10108

Model	Voltage*	Frequency	Propeller rotation speed (0 Pa - 0 inH ₂ O)	Air flow				Absorbed power (0 Pa - 0 in H ₂ O)	Absorbed power (25 Pa - 0.10 inH ₂ O)	Specific power input (0 Pa - 0 inH ₂ O)	Specific power input (25 Pa - 0.10 inH ₂ O)	Ventilating Efficiency Ratio (0 Pa - 0 inH ₂ O)	Ventilating Efficiency Ratio (25 Pa - 0.10 inH ₂ O)
				0 Pa 0 inH ₂ O	12 Pa 0.05 inH ₂ O	25 Pa 0.10 inH ₂ O	50 Pa 0.20 inH ₂ O						
EOS 53/2*	Δ 220-240 V Y 380-420 V	50 Hz	516 RPM	26.200 cfm	25.300 cfm	24.200 cfm	21.700 cfm	1914 W	2019 W	43 W/ (1000m ³ /h)	49 W/ (1000m ³ /h)	13,7 cfm/W	12,0 cfm/W
				44.500 m ³ /h	42.900 m ³ /h	41.100 m ³ /h	36.800 m ³ /h						
EWS 53/2	Δ 220-270 V Y 380-460 V	60 Hz	515 RPM	26.200 cfm	25.200 cfm	24.200 cfm	22.100 cfm	1916 W	2038 W	43 W/ (1000m ³ /h)	50 W/ (1000m ³ /h)	13,7 cfm/W	11,9 cfm/W
				44.600 m ³ /h	42.900 m ³ /h	41.200 m ³ /h	37.500 m ³ /h						
EOS 53/1,5*	Δ 220-240 V Y 380-420 V	50 Hz	473 RPM	24.200 cfm	23.100 cfm	22.000 cfm	19.500 cfm	1491 W	1603 W	36 W/ (1000m ³ /h)	43 W/ (1000m ³ /h)	16,2 cfm/W	13,7 cfm/W
				41.100 m ³ /h	39.300 m ³ /h	37.400 m ³ /h	33.100 m ³ /h						
EWS 53/1,5	Δ 220-270 V Y 380-460 V	60 Hz	473 RPM	24.100 cfm	23.100 cfm	22.000 cfm	19.600 cfm	1496 W	1611 W	37 W/ (1000m ³ /h)	43 W/ (1000m ³ /h)	16,1 cfm/W	13,7 cfm/W
				40.900 m ³ /h	39.200 m ³ /h	37.400 m ³ /h	33.300 m ³ /h						
EOS 53/1*	Δ 220-240 V Y 380-420 V	50 Hz	393 RPM	20.200 cfm	19.000 cfm	17.400 cfm	13.700 cfm	934 W	1021 W	27 W/ (1000m ³ /h)	35 W/ (1000m ³ /h)	21,6 cfm/W	17,0 cfm/W
				34.300 m ³ /h	32.200 m ³ /h	29.500 m ³ /h	23.200 m ³ /h						
EWS 53/1	Δ 220-270 V Y 380-460 V	60 Hz	390 RPM	20.000 cfm	18.700 cfm	17.300 cfm	13.500 cfm	942 W	1045 W	28 W/ (1000m ³ /h)	36 W/ (1000m ³ /h)	21,2 cfm/W	16,5 cfm/W
				34.000 m ³ /h	31.800 m ³ /h	29.300 m ³ /h	23.000 m ³ /h						

EOS / EWS 42 - test number Bess Lab: 12324; 12321; 12317; 12320

EOS 42/1*	Δ 220-240 V Y 380-420 V	50 Hz	579 RPM	14.600 cfm	13.900 cfm	13.100 cfm	11.400 cfm	909 W	978 W	37 W/ (1000m ³ /h)	44 W/ (1000m ³ /h)	16,1 cfm/W	13,4 cfm/W
				24.900 m ³ /h	23.700 m ³ /h	22.300 m ³ /h	19.400 m ³ /h						
EWS 42/1	Δ 220-270 V Y 380-460 V	60 Hz	610 RPM	15.400 cfm	14.800 cfm	14.000 cfm	12.400 cfm	1097 W	1171 W	42 W/ (1000m ³ /h)	49 W/ (1000m ³ /h)	14,0 cfm/W	12,0 cfm/W
				26.200 m ³ /h	25.100 m ³ /h	23.800 m ³ /h	21.000 m ³ /h						
EOS 42/0,75*	Δ 220-240 V Y 380-420 V	50 Hz	525 RPM	13.300 cfm	12.400 cfm	11.600 cfm	9.400 cfm	724 W	784 W	32 W/ (1000m ³ /h)	40 W/ (1000m ³ /h)	18,3 cfm/W	14,8 cfm/W
				22.600 m ³ /h	21.100 m ³ /h	19.700 m ³ /h	16.000 m ³ /h						
EWS 42/0,75	Δ 220-270 V Y 380-460 V	60 Hz	527 RPM	13.300 cfm	12.600 cfm	11.700 cfm	9.600 cfm	741 W	804 W	33 W/ (1000m ³ /h)	40 W/ (1000m ³ /h)	17,9 cfm/W	14,5 cfm/W
				22.500 m ³ /h	21.300 m ³ /h	19.900 m ³ /h	16.300 m ³ /h						

Tested according to ANSI/AMCA 210-07 ANSI/ASHRAE 51-07 complying with ASABE/S565 OCT 2005.

*Single phase motors, different voltage and speed regulable motors over transformers are available on request.

Note: All fans tested with shutter and protection net.



Performance diagrams

cfm

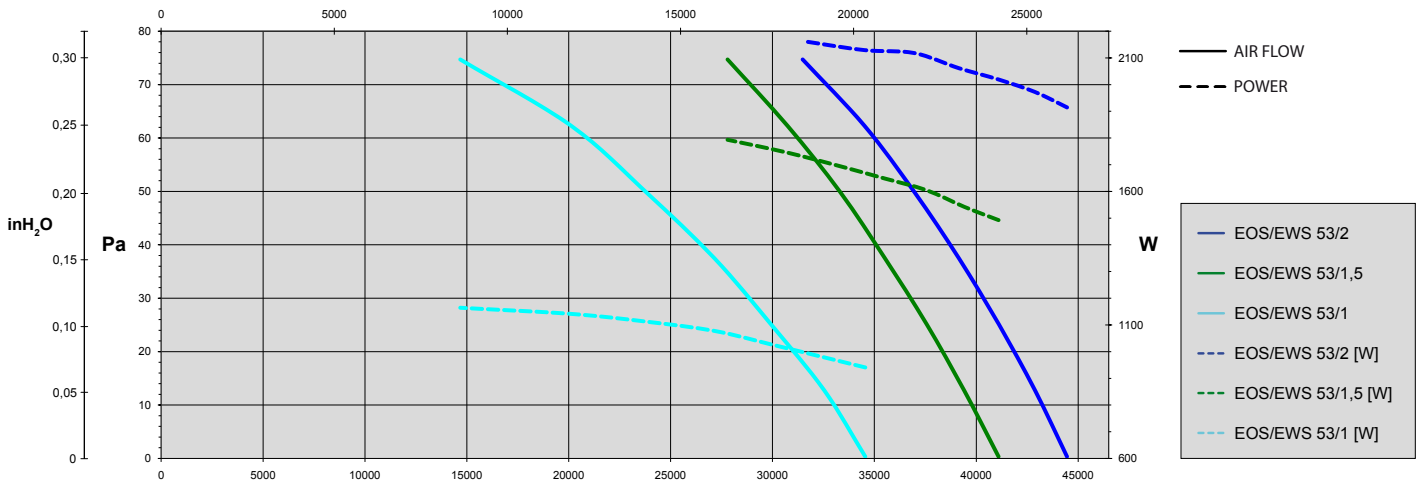

Performance diagrams referred to 50Hz versions

m³/h



Performance diagrams

EOS EWS

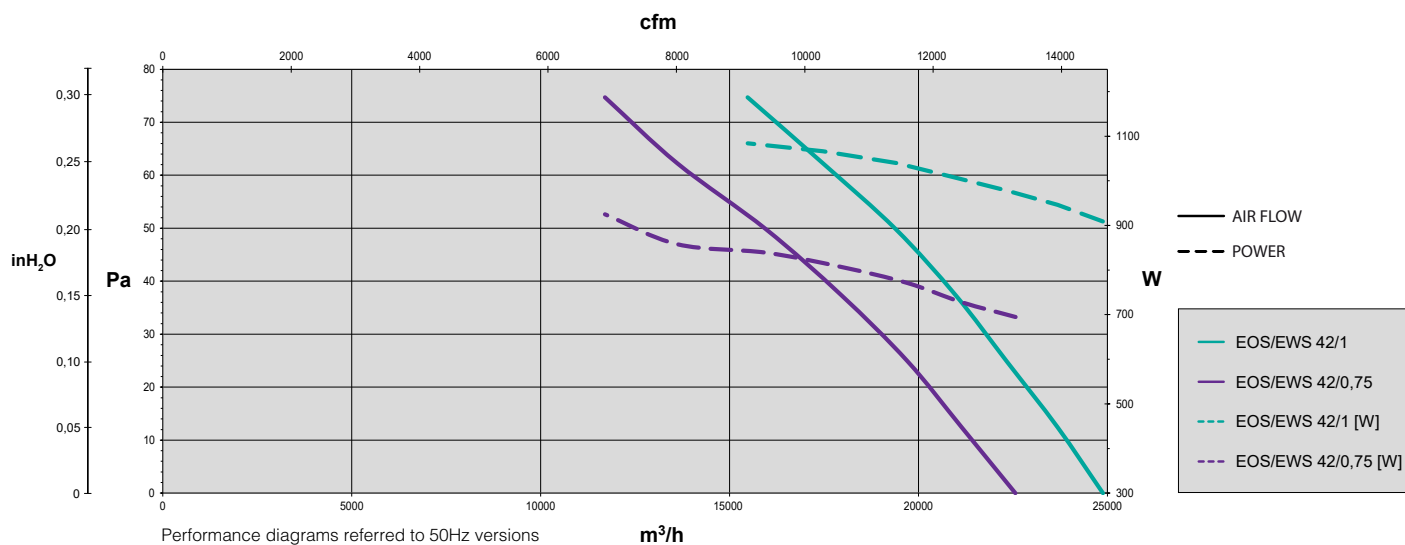

Dimensions and loading possibilities

Dimensions	EOS / EWS 53	EOS / EWS 42
Dimension - A - [mm]	1380	1145
Dimension - B - [mm]	1380	1145
Dimension - C - [mm]	400	400
Dimension - E - [mm]	515	515
Dimension - F - [mm]	114	109
Dimension - G - [mm]	292	225
Dimension - H - [mm]	795	692
Dimension - D - [mm]	1340	1060
Sound pressure level Lpa* [dB]	74,8-68,4	72,7-68,2
Weight** [kg]	80-69	54-50

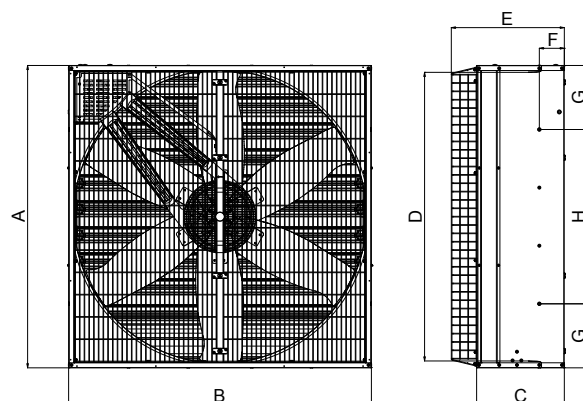

*Measurement surface according to UNI EN ISO 3744 pic C.7

**The weight depends on chosen configuration.

Loading possibilities on pallet		
Fully assembled version (FA)	EOS / EWS 53	EOS / EWS 42
LxWxH [mm]	1200x1400x1550	1200x1200x2200
N° pieces	3	5
Gross weight - kg	250	270

Loading possibilities				
Model	Fully assembled version (FA)		Knock-down version (KD)	
	53	42	53	42
Container 20ft	28	50	180	250
Container 40ft	58	102	300	450
Container 40ft HC	66	124	---	---
Truck	74	140	360	500

EWD

DIRECT DRIVEN EXHAUST FAN

EWD exhaust fan is available in 26", 31" and 37". The direct drive ensures a greater efficiency by reducing energy losses. The patented centrifugal opening system guarantees a complete shutter opening already at 40% of the nominal rotation speed.

Thanks to the completely redesigned opening system of EWD fans, the noise level has been reduced and the fan efficiency has been increased. The wallhousing is available in galvanized or stainless steel (Aeternum 31" only) for the maximum corrosion resistance.

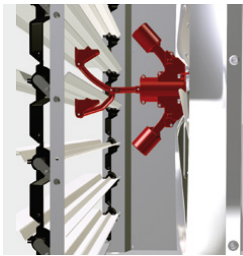

Models 26 and 37

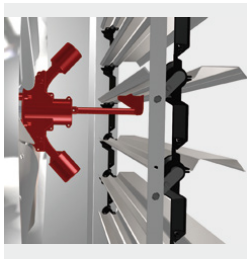

Model 31

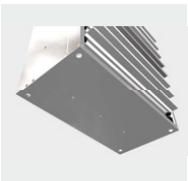

Bottom panel
with 4 practical water
discharge holes

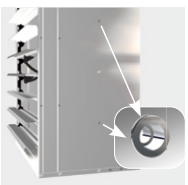

Fixing threaded
bush (M8)

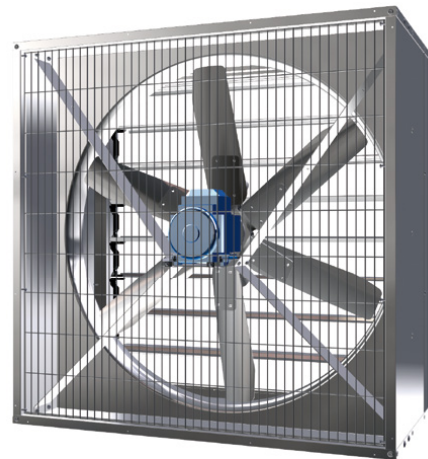

 MADE IN ITALY

 **TERMOTECNICA®**
PERICOLI

Technical features



EWD 26 - 31 - 37 test number Bess Lab: 16508; 16509; 16504; 16505; 16502; 16503

Model	Voltage*	Frequency	Propeller rotation speed (0 Pa - 0 inH ₂ O)	Air flow				Absorbed power (0 Pa - 0 in H ₂ O)	Absorbed power (25 Pa - 0.10 inH ₂ O)	Specific power input (0 Pa - 0 inH ₂ O)	Specific power input (25 Pa - 0.10 inH ₂ O)	Ventilating Efficiency Ratio (0 Pa - 0 inH ₂ O)	Ventilating Efficiency Ratio (25 Pa - 0.10 inH ₂ O)
				0 Pa 0 inH ₂ O	12 Pa 0.05 inH ₂ O	25 Pa 0.10 inH ₂ O	50 Pa 0.20 inH ₂ O						
EWD 26/0,5	Δ 220-240 V Y 380-420 V	50 Hz	942 RPM	5640 cfm	5450 cfm	5250 cfm	4780 cfm	429 W	467 W	45,0 W/(1000m ³ /h)	52,0 W/(1000m ³ /h)	13,1 cfm/W	11,2 cfm/W
				9600 m ³ /h	9300 m ³ /h	8900 m ³ /h	8100 m ³ /h						
	Δ 220-270 V Y 380-460 V	60 Hz	1123 RPM	5650 cfm	5440 cfm	5250 cfm	4810 cfm						
				9600 m ³ /h	9200 m ³ /h	8900 m ³ /h	8200 m ³ /h						
EWD 31/0,75	Δ 220-240 V Y 380-420 V	50 Hz	935 RPM	9080 cfm	8760 cfm	8400 cfm	7710 cfm	645 W	695 W	42,0 W/(1000m ³ /h)	49,0 W/(1000m ³ /h)	14,1 cfm/W	12,1 cfm/W
				15400 m ³ /h	14900 m ³ /h	14300 m ³ /h	13100 m ³ /h						
	Δ 220-270 V Y 380-460 V	60 Hz	1115 RPM	8870 cfm	8510 cfm	8200 cfm	7540 cfm						
				15100 m ³ /h	14500 m ³ /h	13900 m ³ /h	12800 m ³ /h						
EWD 37/0,75	Δ 220-240 V Y 380-420 V	50 Hz	935 RPM	10720 cfm	10240 cfm	9720 cfm	8650 cfm	633 W	693 W	35,0 W/(1000m ³ /h)	42,0 W/(1000m ³ /h)	16,9 cfm/W	14,0 cfm/W
				18200 m ³ /h	17400 m ³ /h	16500 m ³ /h	14700 m ³ /h						
	Δ 220-270 V Y 380-460 V	60 Hz	1109 RPM	11600 cfm	10960 cfm	10260 cfm	8870 cfm						
				19700 m ³ /h	18600 m ³ /h	17400 m ³ /h	15100 m ³ /h						

Tested according to ANSI/AMCA 210-07 ANSI/ASHRAE 51-07 complying with ASABE/S565 OCT 2005.

*Single phase motors, different voltage and speed regulable motors over transformers are available on request only on EWD 26.

Note: All fans tested with shutter and protection net.



Dimensions and loading possibilities

Dimensions	EWD 26	EWD 31	EWD 37
Dimension - A - [mm]	790	905	1025
Dimension - B - [mm]	790	907	1025
Dimension - C - [mm]	530	530	530
Dimension - D - [mm]	645	645	645
Dimension - E - [Ø mm]	638	780	930
Dimension - F - [mm]	241,5	252,5	226,5
Dimension - G - [mm]	203	225	255
Dimension - H - [mm]	380	455	513
Sound pressure level Lpa* [dB]	69	74,7	81,9
Gross weight [kg]	41	48	53

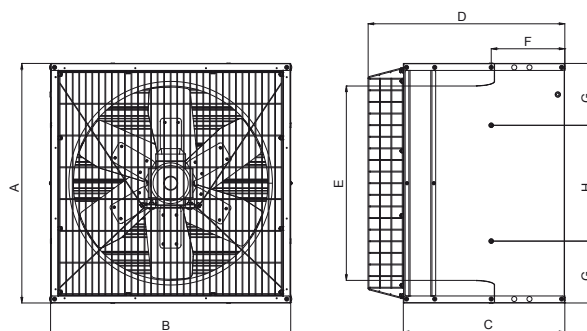

*Measurement surface according to UNI EN ISO 3744 pic C.7

Loading possibilities on pallet	EWD 26		EWD 31		EWD 37	
Fully assembled version (FA)	Type A	Type B	Type A	Type A	Type A	Type A
LxWxH [mm]	800x800x1800	800x1330x1800	910x1070x1950	910x1070x1950	1030x1060x1800	1030x1060x1800
N° pieces	3	5	4	4	3	3
Gross weight - kg	131	212	200	200	170	170

Loading possibilities

	Fully assembled version (FA)			Knock-down version (KD)		
	EWD 26	EWD 31	EWD 37	EWD 26	EWD 31	EWD 37
Container 20ft	70	48	40	300	280	250
Container 40ft	150	104	88	600	560	450
Container 40ft HC	180	130	88			
Camion STD / Camion H 2,60	190 / 228	112 / 140	104	600	600	500

Exhaust fan with air outlet cone in the version **53s**". Thanks to the "Venturi effect" the fan can achieve a very high efficiency and a reduction of operational costs. Wallhousing and shutter blades in galvanized steel ensure high corrosion resistance even in very aggressive environments. The fan has been tested in our PERlab and certified by BessLab

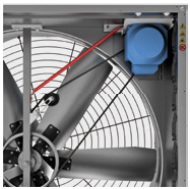
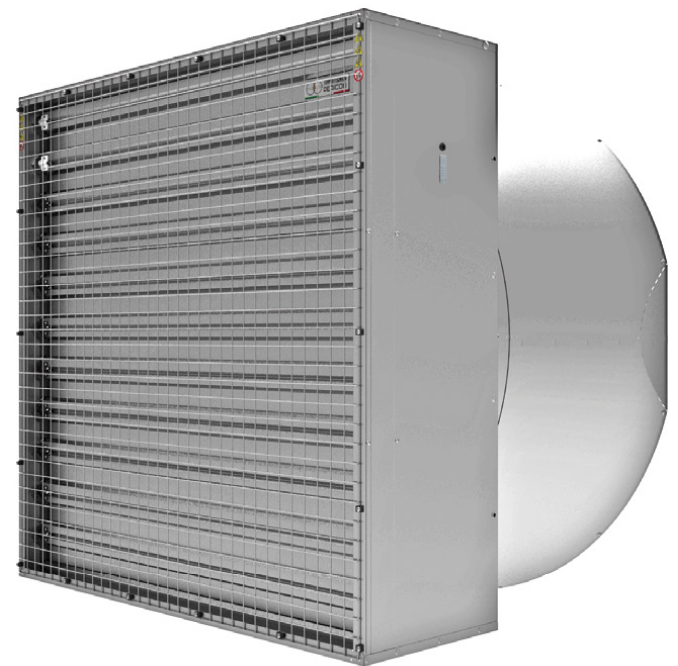

Sturdy and practical motor fixing system



Removable shutter blades for easy maintenance/inspection



ABT Automatic belt tensioner (optional)



Bottom panel with practical water discharge holes.

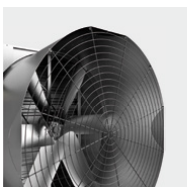

Security grid on the squared cone



NT Safety net on air intake side (optional)

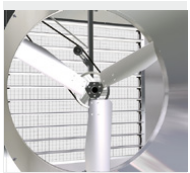

Aerodynamic profiled 3- or 6-blade-propeller



Features and advantages



The cone special shape, which has the same outer dimensions of the fan's body, permits to install more **EOC 56** in comparison to similar products.

Body in galvanised steel, propeller and shutter blades in aluminium alloy guarantee the necessary protection also in harsh environments. Tested in our PERIlab.

Dimensions and loading possibilities

Characteristics	EOC 53s	EOC 56
Sound pressure level Lpa* [dB]	70.7-65.3	72.1-75.6
Weight [kg]	98-89	109-112

*Measurement surface according to UNI EN ISO 3744 pic C.7

Loading possibilities on pallet	EOC 53s	EOC 56
Fully assembled version (FA)*		
LxWxH - mm	2290x1500x2100	2290x1700x2270
N° pieces	5	5
Gross weight - kg	600	600

Loading possibilities	EOC 53s		EOC 56	
	Fully assembled version (FA)*	Knock-down version (KD)	Fully assembled version (FA)*	Knock-down version (KD)
Container 20ft	20	125	16	100
Container 40ft	40	250	36	200
Container 40ft HC	40	260	36	220
Truck	45	260	41	250

*Fan body and shutter are delivered pre-assembled, whereas the cone (in sectors), brackets and front cone safety nets are delivered separately in flat pack form.

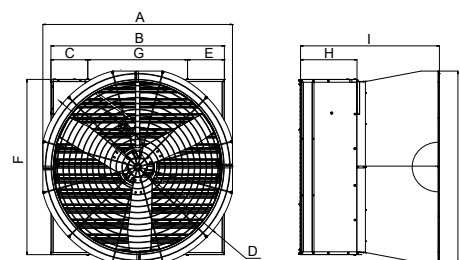

Dimension	EOC 53s
Dimension - A - [mm]	1515
Dimension - B - [mm]	1382
Dimension - C - E [mm]	293.5
Dimension - D - [mm]	1562
Dimension - F - [mm]	1380
Dimension - G - [mm]	795
Dimension - H - [mm]	450
Dimension - I - [mm]	1110
Dimension - L - [mm]	1515

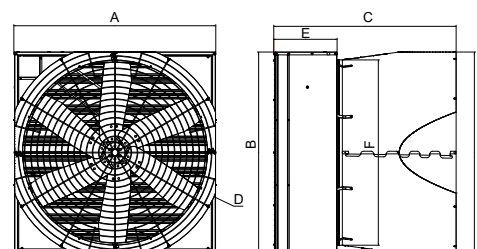

Dimension	EOC 56
Dimension - A - [mm]	1537
Dimension - B - [mm]	1530
Dimension - C - [mm]	1388
Dimension - D - [ø mm]	1650
Dimension - E - [mm]	482
Dimension - F - [ø mm]	1400
Dimension - G - [mm]	1530

EOC 53s - Test number Bess Lab: 16467; 16466; 16468; 16499; 16470; 16471; 16478; 16479

Model	Voltage*	Frequency	Propeller rotation speed (0 Pa - 0 inH ₂ O)	Air flow				Absorbed power (0 Pa - 0 inH ₂ O)	Absorbed power (25 Pa - 0.10 inH ₂ O)	Specific power input (0 Pa - 0 inH ₂ O)	Specific power input (25 Pa - 0.10 inH ₂ O)	Ventilating Efficiency Ratio (0 Pa - 0 inH ₂ O)	Ventilating Efficiency Ratio (25 Pa - 0.10 inH ₂ O)
				0 Pa	12 Pa	25 Pa	50 Pa						
				0 inH ₂ O	0.05 inH ₂ O	0.10 inH ₂ O	0.20 inH ₂ O						
EOC 53s / 2-3	Δ 220-240 V Y 380-420 V	50 Hz	541 RPM	29.600 cfm	28.100 cfm	26.500 cfm	22.700 cfm	1490 W	1625 W	30 W/(1000m³/h)	36 W/(1000m³/h)	19,8 cfm/W	16,3 cfm/W
				50.300 m³/h	47.700 m³/h	45.100 m³/h	38.500 m³/h						
	Δ 220-270 V Y 380-460 V	60 Hz	543 RPM	29.600 cfm	28.200 cfm	26.600 cfm	22.900 cfm	1484W	1618 W	30 W/(1000m³/h)	36 W/(1000m³/h)	19,9 cfm/W	16,4 cfm/W
				50.300 m³/h	47.900 m³/h	45.200 m³/h	38.800 m³/h						
EOC 53s / 2-6	Δ 220-240 V Y 380-420 V	50 Hz	451 RPM	27.200 cfm	26.100 cfm	25.000 cfm	21.800 cfm	1281 W	1435 W	28 W/(1000m³/h)	34 W/(1000m³/h)	21,2cfm/W	17,4 cfm/W
				46.200 m³/h	44.300 m³/h	42.500 m³/h	37.100 m³/h						
	Δ 220-270 V Y 380-460 V	60 Hz	448 RPM	27.100 cfm	25.800 cfm	24.500 cfm	20.900 cfm	1228 W	1383 W	27 W/(1000m³/h)	33 W/(1000m³/h)	22,1cfm/W	17,7 cfm/W
				46.100 m³/h	43.800 m³/h	41.600 m³/h	35.500 m³/h						
EOC 53s / 1,5-6*	Δ 220-240 V Y 380-420 V	50 Hz	433 RPM	26.200 cfm	25.100 cfm	23.900 cfm	19.800 cfm	1137 W	1274 W	26 W/(1000m³/h)	31 W/(1000m³/h)	23 cfm/W	18,7 cfm/W
				44.500 m³/h	42.600 m³/h	40.500 m³/h	33.600 m³/h						
	Δ 220-270 V Y 380-460 V	60 Hz	435 RPM	26.200 cfm	25.300 cfm	24.000 cfm	20.800 cfm	1145 W	1286 W	26 W/(1000m³/h)	32 W/(1000m³/h)	22,9 cfm/W	18,6 cfm/W
				44.500 m³/h	42.900 m³/h	40.700 m³/h	35.400 m³/h						
EOC 53s / 1-6*	Δ 220-240 V Y 380-420 V	50 Hz	369 RPM	22.600 cfm	21.200 cfm	19.500 cfm	13.700 cfm	783 W	907 W	20 W/(1000m³/h)	27 W/(1000m³/h)	28,9 cfm/W	21,5 cfm/W
				38.400 m³/h	36.100 m³/h	33.100 m³/h	23.300 m³/h						
	Δ 220-270 V Y 380-460 V	60 Hz	378 RPM	23.100 cfm	21.800 cfm	20.200 cfm	15.400 cfm	855 W	983 W	22 W/(1000m³/h)	29 W/(1000m³/h)	27 cfm/W	20,6 cfm/W
				39.200 m³/h	37.000 m³/h	34.400 m³/h	26.200 m³/h						

Tested according to ANSI/AMCA 210-07 ANSI/ANSRAE 51-07 complying with ASABE/S565 OCT 2005.
 *Single phase motors, different voltage and speed regulable motors over transformers are available on request.
Note: All fans tested with shutter and net.



EOC 56 - Test number Bess Lab: 22351; 22353; 22347; 22349; 22352; 22354; 22348; 22350

Model	Voltage	Frequency	Propeller rotation speed (0 Pa - 0 inH ₂ O)	Air flow					Absorbed power (0 Pa - 0 inH ₂ O)	Absorbed power (25 Pa - 0.10 inH ₂ O)	Specific power input (0 Pa - 0 inH ₂ O)	Specific power input (25 Pa - 0.10 inH ₂ O)	Ventilating Efficiency Ratio (0 Pa - 0 inH ₂ O)	Ventilating Efficiency Ratio (25 Pa - 0.10 inH ₂ O)
				0 Pa	25 Pa	50 Pa	75 Pa	100 Pa						
				0 inH ₂ O	0.10 inH ₂ O	0.20 inH ₂ O	0.30 inH ₂ O	0.40 inH ₂ O						
EOC 56-3/2	Δ 220-270 V Y 380-460 V	50 Hz	538 RPM	33.400 cfm	30.400 cfm	26.900 cfm	21.300 cfm	12.400 cfm	1567 W	1696 W	28 W/(1000m³/h)	33 W/(1000m³/h)	21,3 cfm/W	17,9 cfm/W
				56.700 m³/h	51.600 m³/h	45.700 m³/h	36.200 m³/h	21.100 m³/h						
	Δ 220-270 V Y 380-460 V	60 Hz	536 RPM	33.200 cfm	30.300 cfm	26.700 cfm	22.200 cfm	12.000 cfm	1542 W	1671 W	27 W/(1000m³/h)	32 W/(1000m³/h)	21,5 cfm/W	18,1 cfm/W
				56.300 m³/h	51.500 m³/h	45.300 m³/h	37.700 m³/h	20.300 m³/h						
EOC 56-6/2	Δ 220-270 V Y 380-460 V	50 Hz	482 RPM	31.000 cfm	28.900 cfm	26.600 cfm	23.300 cfm	17.700 cfm	1468 W	1634 W	28 W/(1000m³/h)	33 W/(1000m³/h)	21,1 cfm/W	17,1 cfm/W
				52.600 m³/h	49.100 m³/h	45.200 m³/h	39.600 m³/h	30.000 m³/h						
	Δ 220-270 V Y 380-460 V	60 Hz	479 RPM	30.700 cfm	28.700 cfm	26.200 cfm	22.600 cfm	17.000 cfm	1429 W	1603 W	27 W/(1000m³/h)	33 W/(1000m³/h)	21,5 cfm/W	17,9 cfm/W
				52.200 m³/h	48.700 m³/h	44.500 m³/h	38.500 m³/h	28.900 m³/h						
EOC 56-3/1,5	Δ 220-270 V Y 380-460 V	50 Hz	481 RPM	29.900 cfm	26.400 cfm	21.700 cfm	12.400 cfm	-	1128 W	1235 W	22 W/(1000m³/h)	27 W/(1000m³/h)	26,5 cfm/W	21,4 cfm/W
				50.800 m³/h	44.900 m³/h	36.900 m³/h	21.100 m³/h	-						
	Δ 220-270 V Y 380-460 V	60 Hz	480 RPM	29.800 cfm	26.200 cfm	21.600 cfm	12.100 cfm	-	1115 W	1223 W	22 W/(1000m³/h)	27 W/(1000m³/h)	26,7 cfm/W	21,4 cfm/W
				50.600 m³/h	44.500 m³/h	36.700 m³/h	20.500 m³/h	-						
EOC 56-6/1,5	Δ 220-270 V Y 380-460 V	50 Hz	433 RPM	27.900 cfm	25.600 cfm	22.700 cfm	17.400 cfm	11.400 cfm	1089 W	1239 W	23 W/(1000m³/h)	28 W/(1000m³/h)	25,6 cfm/W	28 cfm/W
				47.400 m³/h	43.600 m³/h	38.600 m³/h	29.500 m³/h	19.300 m³/h						
	Δ 220-270 V Y 380-460 V	60 Hz	430 RPM	27.700 cfm	25.300 cfm	22.400 cfm	17.400 cfm	10.600 cfm	1062 W	1212 W	23 W/(1000m³/h)	28 W/(1000m³/h)	26,1 cfm/W	20,9 cfm/W
				47.100 m³/h	43.000 m³/h	38.000 m³/h	29.500 m³/h	18.000 m³/h						

Tested according to ANSI/AMCA 210-07 ANSI/ANSRAE 51-07 complying with ASABE/S565 OCT 2005.
Note: All fans tested with shutter and net.



VERSIONS, SUPPLEMENTS AND ACCESSORIES

Shutter versions

EOS

STANDARD galvanised steel

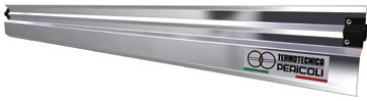

AS

aluminium shutter

EWS EWD

STANDARD galvanised steel



AETERNUM

structure, propeller and shutter in AISI 304
(only for models 31 e 53)

EOC 53_s

STANDARD galvanised steel

AS aluminium shutter



EOC 56

STANDARD aluminium alloy

Fan versions



STANDARD
galvanised steel

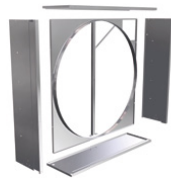

STANDARD
galvanised steel

AETERNUM
structure, propeller and shutter in AISI 304
(only for models 31 e 53)

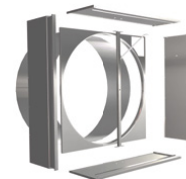

STANDARD
galvanised steel

Versions blade



ALU

aluminium alloy
(preferred version for
its lightness and strength)

(26-31-37-42-56 models only available in ALU version)

GALV

galvanised steel

STS

stainless steel AISI 430

INOX

stainless steel AISI 304

Motors



Model	EOS	EWS/EWD	EOC
MON	optional	optional	optional
3-phase	standard	standard	standard

All three-phase motors can be used with inverter control.

Accessories



FIX fixing strip for
wall installation

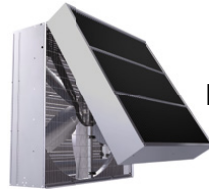

LTP light filter



WPC insulating cover for
long non-working period



microcomputer
modules



TPR
magnetothermic
switch



TPU
motorstarter

All data in this catalogue are indicative and are subject to change without prior notice.

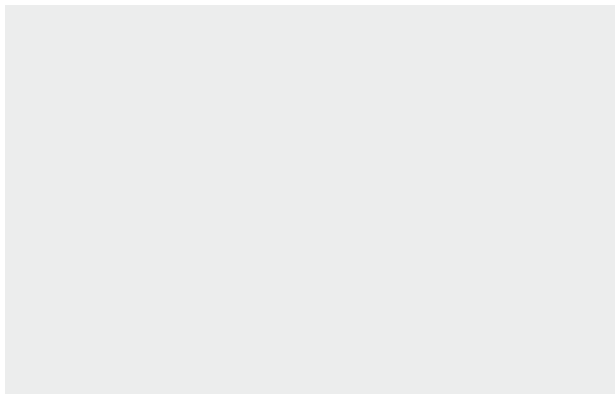

TERMOTECNICA PERICOLI S.r.l.
Regione Rapalline, 44 - 17031 Albenga, Italia
tel. 0182 589006 fax 0182 589005 pit@pericoli.com

PERICOLI ASIA PACIFIC Sdn. Bhd.
pap@pericoli.com

PERICOLI CENTRO AMERICA
pca@pericoli.com

PERICOLI MIDDLE EAST
pme@pericoli.com

pericoli.com



PERICOOL are registered trademarks by Termotecnica Pericoli S.r.l.